

Bu Resim MESA OTO ELEKTRİK LTD.ŞTİ'nin malıdır. Şirket Yetkililerinin izni olmaksızın kopya edilemez, üzerinde değişiklik yapılamaz. This image MESA AUTO ELECTRIC LTD 's are property. Can not be copied without the consent of the company authorized, any changes can be made.

PARÇA KODU PART CODE	PARÇA ADI PART NAME	s ÖLÇÜSÜ (KALINLIK) s MEASURE (THICKNESS)	Malzeme Material	Kaplama Coating
TŞ 2403.40 DP	1 NO KABLO UÇ Ø2.7 =DP=	0.40±0.05	(CuZn30) Pirinç / Brass	_____
TŞ 2403.40 RP	1 NO KABLO UÇ Ø2.7 =RP=	0.40±0.05	(CuZn30) Pirinç / Brass	_____
TŞ 2403.40 RPK	1 NO KABLO UÇ Ø2.7 =RPK=	0.40±0.05	(CuZn30) Pirinç / Brass	Kalay / Sn (3-5µ)
TŞ 2403.50 DP	1 NO KABLO UÇ Ø2.7 =DP=	0.50±0.05	(CuZn30) Pirinç / Brass	_____
TŞ 2403.50 RP	1 NO KABLO UÇ Ø2.7 =RP=	0.50±0.05	(CuZn30) Pirinç / Brass	_____
TŞ 2403.50 RPK	1 NO KABLO UÇ Ø2.7 =RPK=	0.50±0.05	(CuZn30) Pirinç / Brass	Kalay / Sn (3-5µ)
TŞ 2403.50 RÇN	1 NO KABLO UÇ Ø2.7 =RÇN=	0.50±0.05	Nikel kaplı çelik / Nickel plated Steel	Nikel / Ni (≥1.5µ)

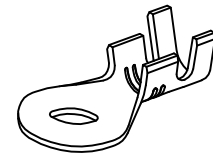

Perspektif  
Perspective

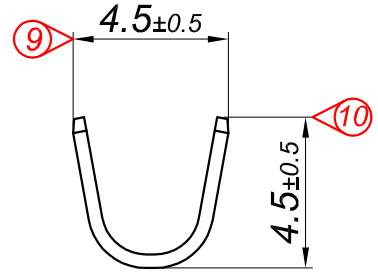
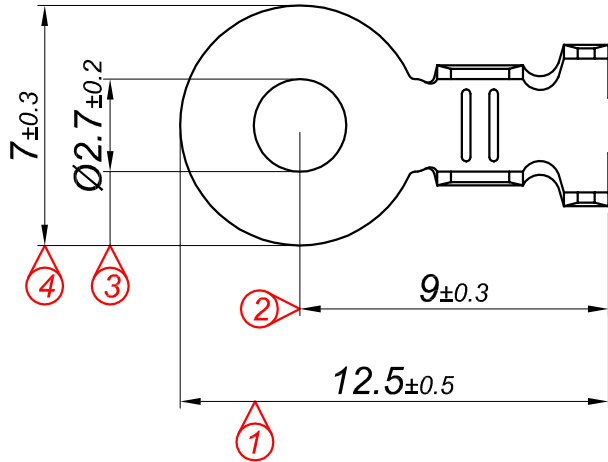
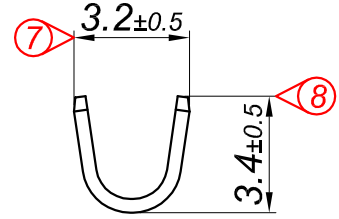
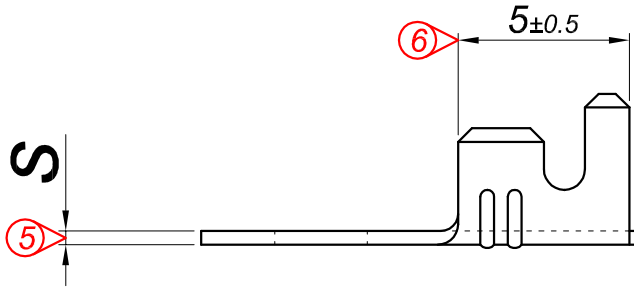
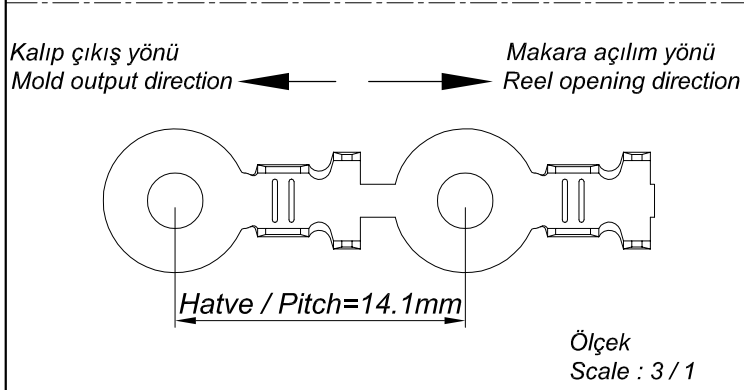

**Kablo Kesiti**  
**Wire Section : 0.50 - 1 mm<sup>2</sup>**

Resim üzerinden ölçü almayınız  
do not measure on drawing

Tarih / Date	19.07.2013	İmza /Signature	Ölçek /Scale		
Çizen / Desing	M.Yağcı				
Onay / Approval	S.Gölcük		5 / 1	No	
				Değişiklik / Revision	Tarih/Date
	Parça Adı: Part Name	1 NO KABLO UÇ Ø2.7		Parça Kodu: Part Code	TŞ 2403